



BITELLI®

BB 621 C

TRACKED PAVER FINISHER



The machine shown can be fitted with additional equipment

ENGINE

Make	Hatz
Type	2M 41L
Cylinders	2
Cooling system	air
Output at 2800 rpm (DIN 6271)	26.4 kW (35.4 HP)
Electric starting	12 V

SPEED

1 st gear (work)	0÷20 m/min
2 nd gear (travel)	0÷3.5 km/h

SCREED RB 260

Hydraulically extending screed width	1.40÷2.60 m
with 2 extensions (0.20 m each) (optional)	max 3.00 m
Laying width reduction (optional)	1.40÷0.50 m
Smoothing plate width	245/210 mm
Screed heating	LPG
Smoothing plate vibration frequency	
3400 rpm	(56.7 Hz)

TECHNICAL SPECS

Transmission	hydrostatic
Track base	1430 mm
Shoe width	200 mm
Ground pressure (hoppers empty)	0.68 kg/cm ²
Inside turning radius	0.70 m
Operating weight	4000 kg
Hopper capacity (tunnel included)	6 t
Hopper discharge height - at centre	490 mm
at sides	525 mm
Ground clearance	185 mm

PERFORMANCES

Max. production	80 t/h
Mat thickness	5÷200 mm

TANK CAPACITIES

Diesel fuel	69 l
Hydraulic oil	73 l
Ecological liquid	22 l

PAVER FINISHER BB 621 C

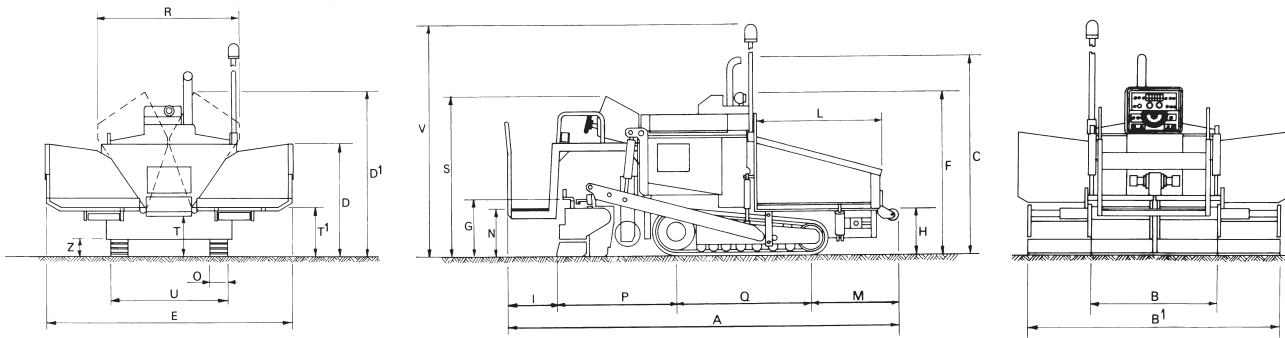

Dimens.	A	B	B'	C	D	D'	E	F	G	H	I	L	M	N	O	P	Q	R	S	T	T'	U	V	Z
mm	4040	1400	2600	1975	1250	1500	2800	1725	610	470	500	1295	840	500	200	1280	1420	1600	1600	490	525	1320	2600	185

CARRIAGE: tracked machine with two rubber shoe crawlers. Crawler tension is automatically controlled by two spring oil pistons. These type of tracks ensure perfect stability, low noise level and excellent levelling performances as they reduce soilslope variations to a minimum.

TRANSMISSION: hydrostatic transmission with two variable displacement pumps feeding two variable displacement axial piston motors directly splined to the planetary final reduction gears in oil bath. Machine advancement is obtained by an electrical control.

An electro-hydraulic servo-control consents machine starting and stopping (for asphalt supply, etc.) with no preset working speed variation.

Machine steering is operated by a steering wheel that controls the variable displacement pumps electric servo-controls. This system guarantees a gradual and precise steering.

SCREED RB 260: fitted with two central fixed elements and two hydraulically operated side mobile elements. The two side elements slide on a chromium plated telescopic and fixed guide. Bushes are oversized to resist shocks and vibrations.

Smoothing plates are made from wear resisting shape-retaining steel and are heated by four LPG burners, one fitted to each element.

Screed vibration is hydraulically controlled and applied to all the screed length.

Variable paving width is obtained by electro-hydraulic distributors.

The screed plate axis allows modifications of shapes (VA WM) with different camber angles between +4.5% and -2.5%.

Other adjustments allow recovery of the smoothing plate wear.

BRAKES: the hydrostatic drive acts as the service brake; the parking brake is a mechanical multi-disk brake with negative hydraulic control.

OPERATOR'S POSITION: the operator drives the paver from the platform positioned behind the screed. The platform is fitted with a pressure sensitive microswitch that indicates the operator's presence.

All machine operations are controlled by simple controls.

HOPPER AND FEEDING SYSTEM: the independent movement of the two side wings is obtained by two hydraulic cylinders. The bottom plate of the hopper is built of abrasion-proof steel.

The conveyor is made of wear-resisting steel.

The material conveyed is spread by two independently controlled reversible augers. Four automatic stop feed devices control conveyor and augers operation.

By raising the screed, the augers height can be adjusted to facilitate side paving and reduction paving group assembling as well as machine loading for transportation.

ELECTRIC SYSTEM: 12 V system with 1 battery 100 A.h. Work lights fitted.

CONTROLS: the machine is hydraulically controlled and driven by simple switches and levers. In case of breakdown all solenoid valves of the hydraulic system can be manually operated.

All main components are at easy reach for maintenance and repair work.

ON REQUEST:

- Automatic LEVELLING devices:
 - GRADE control
 - SLOPE control
 - DIGITAL SLOPE control
- CENTRAL PAVING WIDTH REDUCTION ELEMENTS to 0,50 m
- MECHANICAL EXTENSION ELEMENTS with auger extensions for paving widths up to 3 m
- RIGHT SIDE PAVING GROUP from 0,15 m to 0,60 m (up to 1 m if the machine is equipped with mechanical extensions) BITELLI PATENT
- BURNERS ELECTRONIC IGNITION with automatic adjustment of screed temperature
- LIGHTING SYSTEM for ROAD CIRCULATION



Via IV Novembre, 2 - 40061 MINERBIO (Bologna) - ITALY
Tel. 051 6607111 / 051 6605066 - Fax 051 6605576

Sales Department:

Fax 051 6604142

E-mail: info@bitelli.it - Home Page: <http://www.bitelli.com>